



# AXIAL VALVE RPE

---



LEADER IN FLUID MANAGEMENT CONTROL



# CHARACTERISTICS



- 2/2 WAY DN 8 - UNIDIRECTIONAL
- CONTROL: NORMALLY CLOSED, LATCHING
- WORKING PRESSURE: 0,5-10 bar (7.25-145PSI)
- FLUID TEMPERATURE: T<sub>m</sub> 90°C (194°F)



# EASY MOUNTING

## OUTLET

QUICK COUPLING  
PUSH FIT 8 mm

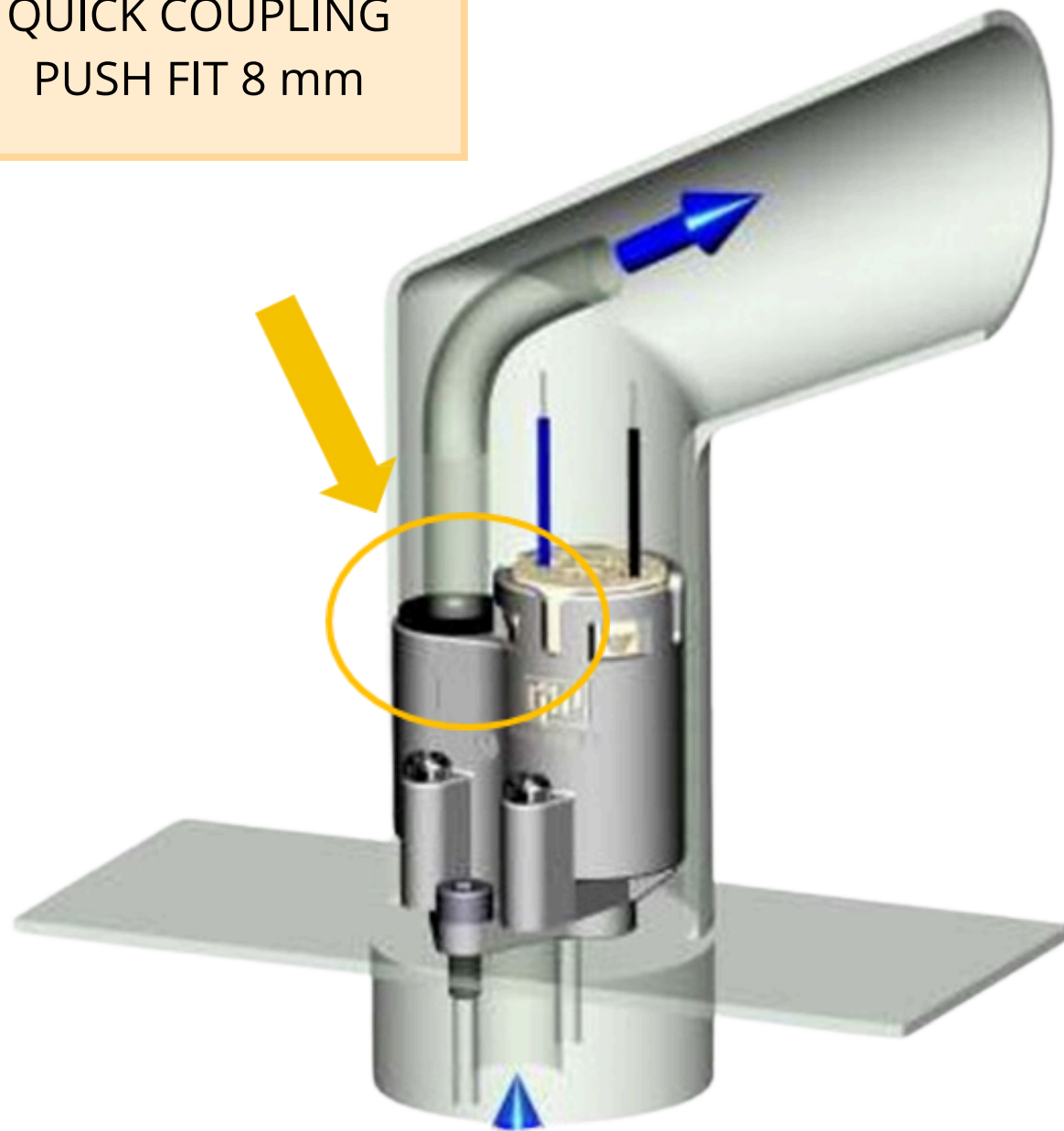

## MAX PRESSURE

10 bar

## Kv VALUE

13,58 L/min

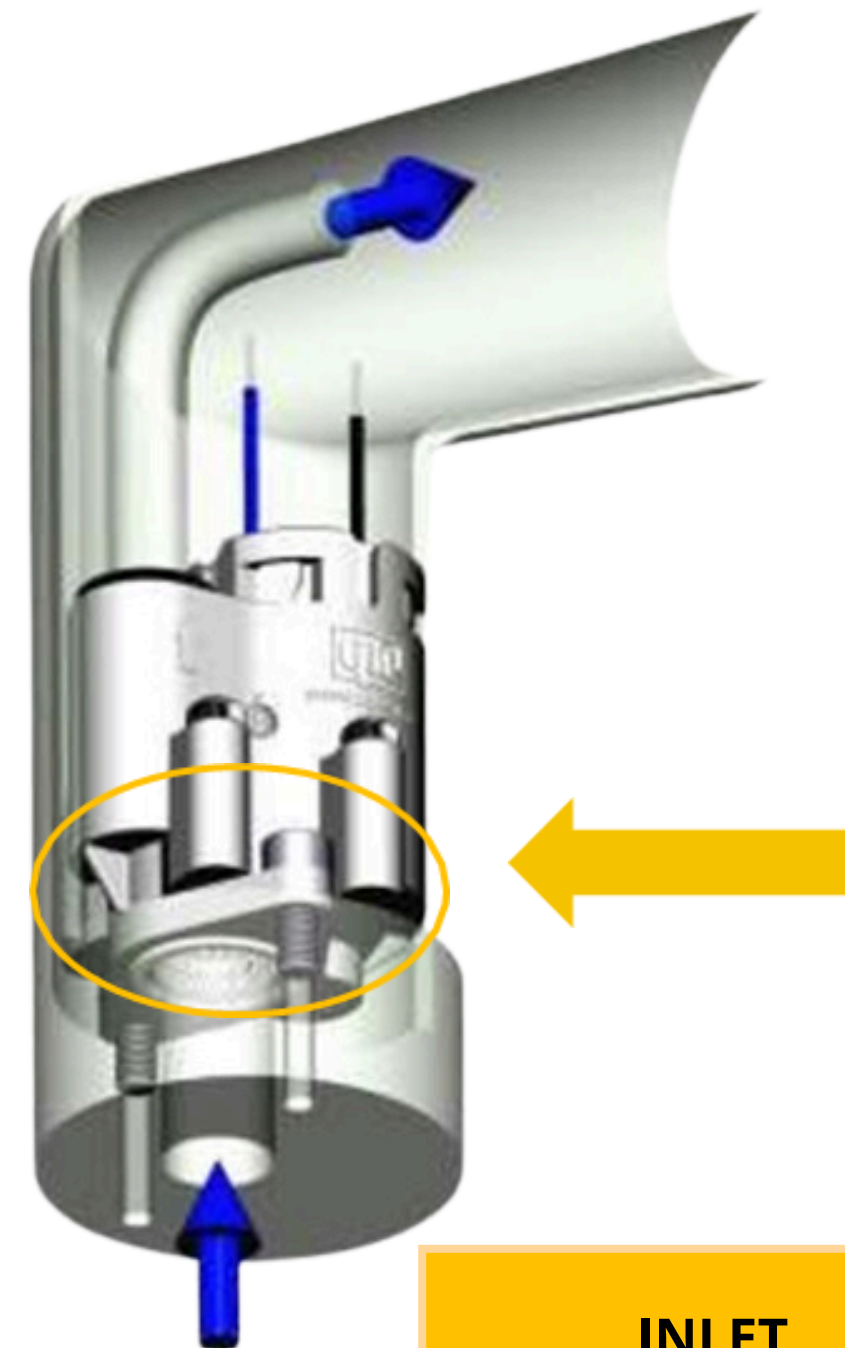

## INLET

FLANGE AT BASE  
2 SCREWS



# COMPACT AND PERFORMANT

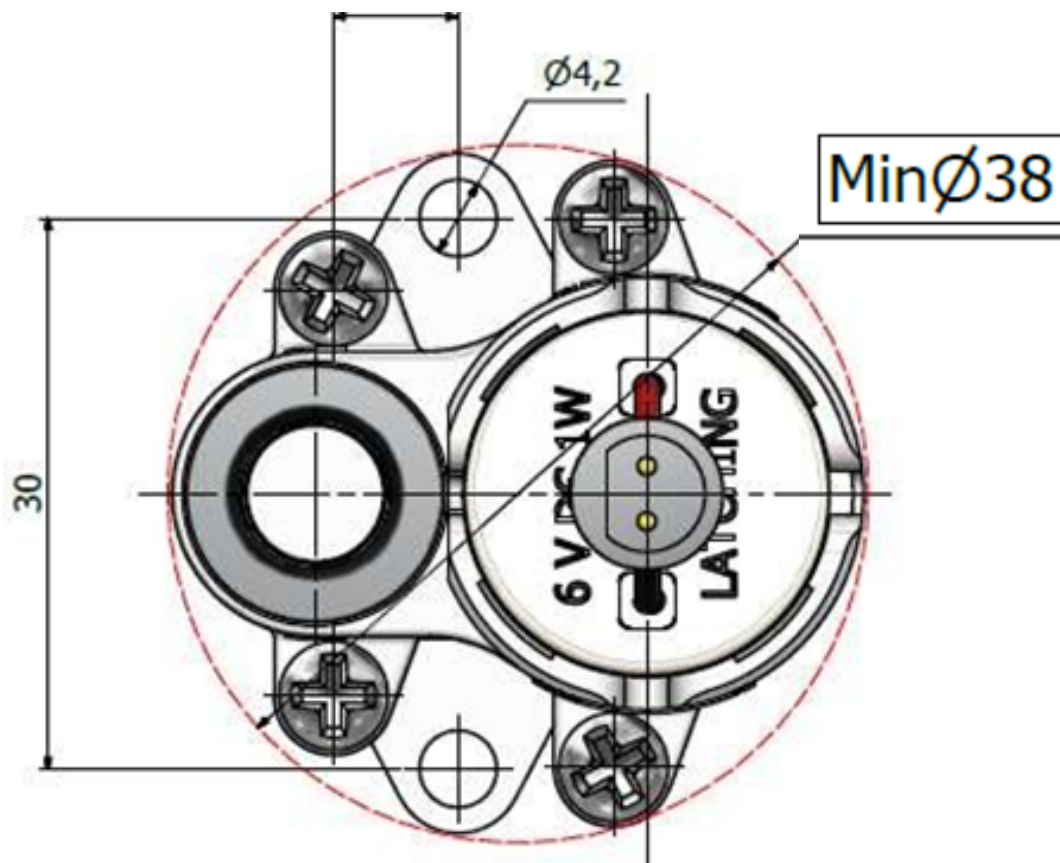

- DIAMETER: 38 mm

- HEIGHT: 46,5 mm

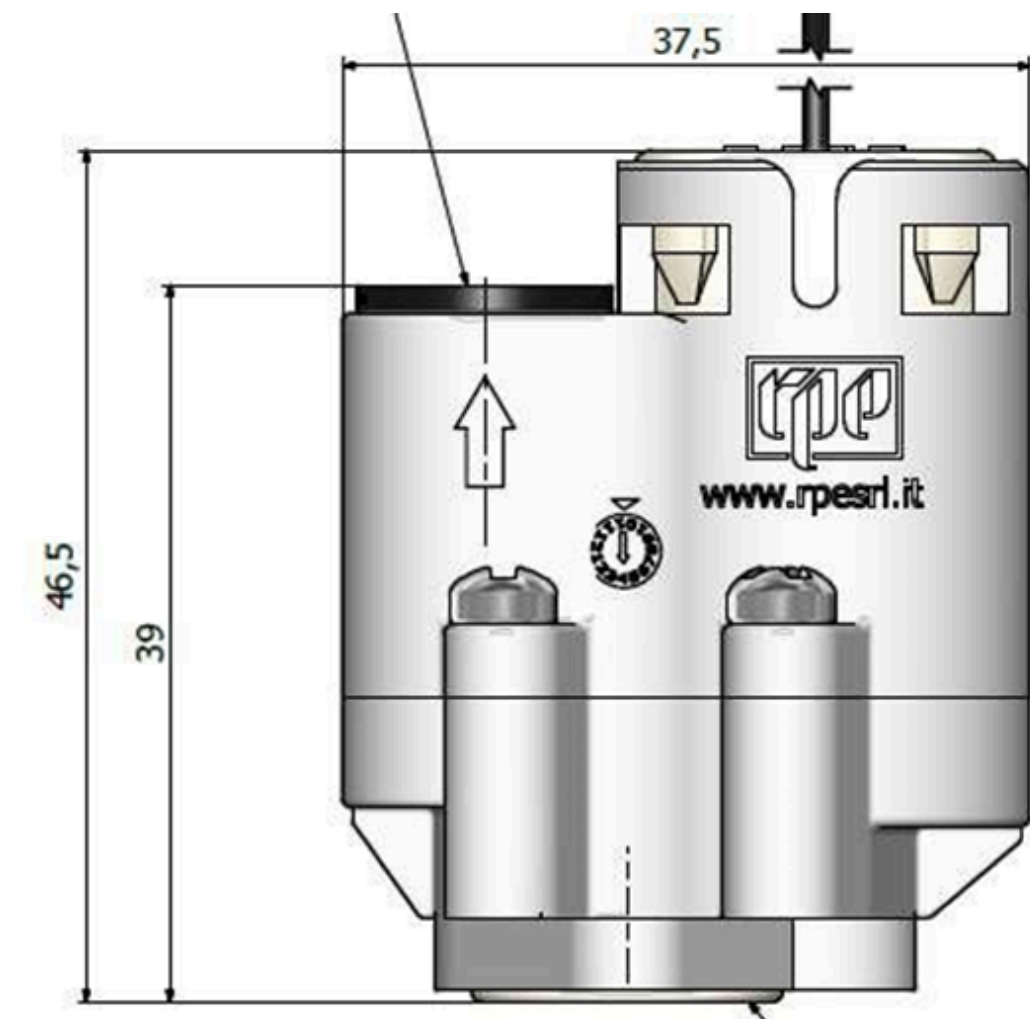

**STANDARD**

INLET FILTER 50 MESH





# ELECTRICAL FEATURES



AXIAL RPE	POWER (20°C)	CONSUMPTION (20°C)	RESPONSE TIME
3V LATCHING	1 W	330 mA	15mS
6V LATCHING	1 W	165 mA	15mS
12V DC NC	1,6 W	130 mA	15mS
24V DC NC	1,6 W	130 mA	15mS



# ELECTRICAL CONNECTIONS

## STANDARD

FLYING CABLES  
LENGHT 200 mm

## OPTION

MALE OR FEMALE CONNECTORS IP 65 CABLE  
LENGHT 100 mm







# THANKS FOR WATCHING

“NOTHING GREAT HAS EVER BEEN DONE WITHOUT PASSION”

---